

Please check the examination details below before entering your candidate information

Candidate surname

Other names

Centre Number

Candidate Number

--	--	--	--	--

--	--	--	--

## Pearson Edexcel International Advanced Level

Time 1 hour 30 minutes

Paper  
reference

**WPH12/01**

### Physics

International Advanced Subsidiary/Advanced Level  
**UNIT 2: Waves and Electricity**

**You must have:**

Scientific calculator, ruler, protractor

Total Marks

### Instructions

- Use **black** ink or ball-point pen.
- **Fill in the boxes** at the top of this page with your name, centre number and candidate number.
- Answer **all** questions.
- Answer the questions in the spaces provided  
– *there may be more space than you need.*
- **Show all your working out** in calculations and **include units** where appropriate.

### Information

- The total mark for this paper is 80.
- The marks for **each** question are shown in brackets  
– *use this as a guide as to how much time to spend on each question.*
- In the question marked with an **asterisk** (\*), marks will be awarded for your ability to structure your answer logically, showing how the points that you make are related or follow on from each other where appropriate.
- The list of data, formulae and relationships is printed at the end of this booklet.

### Advice

- Read each question carefully before you start to answer it.
- Try to answer every question.
- Check your answers if you have time at the end.

Turn over ►

P70969RA

©2022 Pearson Education Ltd.

Q:1/1/1



P 7 0 9 6 9 R A 0 1 2 8



Pearson

## SECTION A

Answer ALL questions.

For questions 1–10, in Section A, select one answer from A to D and put a cross in the box . If you change your mind, put a line through the box  and then mark your new answer with a cross .

- 1 A ray of light is incident on the boundary between two materials, x and y, as shown. The refractive index value for material x is  $n_x$  and for material y is  $n_y$ .

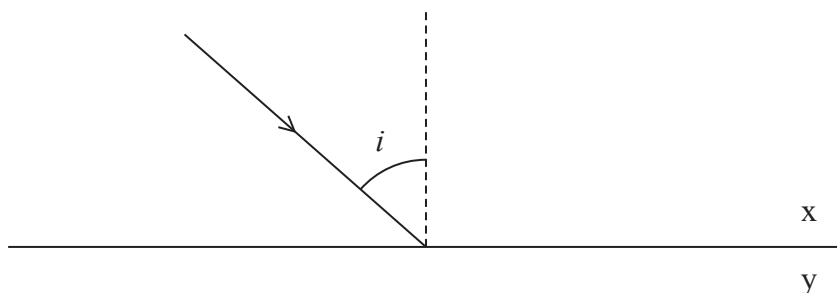

Which row of the table gives the conditions required for total internal reflection to take place at this boundary?

	Condition 1	Condition 2
<input type="checkbox"/> A	$i > \text{critical angle}$	$n_x > n_y$
<input type="checkbox"/> B	$i > \text{critical angle}$	$n_x < n_y$
<input type="checkbox"/> C	$i < \text{critical angle}$	$n_x > n_y$
<input type="checkbox"/> D	$i < \text{critical angle}$	$n_x < n_y$

(Total for Question 1 = 1 mark)



- 2 The graph shows how the displacement  $x$  of particles in a wave varies with time  $t$ . The speed of the wave is not known.

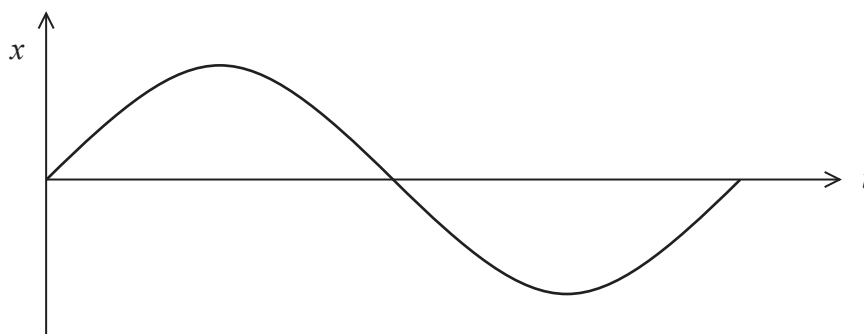

Which of the following can **not** be determined from a graph of displacement against time for the particles in a wave?

- A amplitude  
 B frequency  
 C period  
 D wavelength

(Total for Question 2 = 1 mark)

- 3 When the distance between the Sun and the planet Mercury is  $4.60 \times 10^{10}$  m, the intensity of solar radiation at the surface of Mercury is  $1.45 \times 10^4 \text{ W m}^{-2}$ .

Which of the following expressions gives the power of the Sun?

- A  $(1.45 \times 10^4) (\pi) (4.60 \times 10^{10})^2$   
 B  $(1.45 \times 10^4) (4\pi) (4.60 \times 10^{10})^2$   
 C  $\frac{(1.45 \times 10^4)}{(\pi)(4.60 \times 10^{10})^2}$   
 D  $\frac{(1.45 \times 10^4)}{(4\pi)(4.60 \times 10^{10})^2}$

(Total for Question 3 = 1 mark)

- 4 A ray of unpolarised light is incident on a polarising filter. The polarising filter transmits light of intensity  $I$ , as shown.

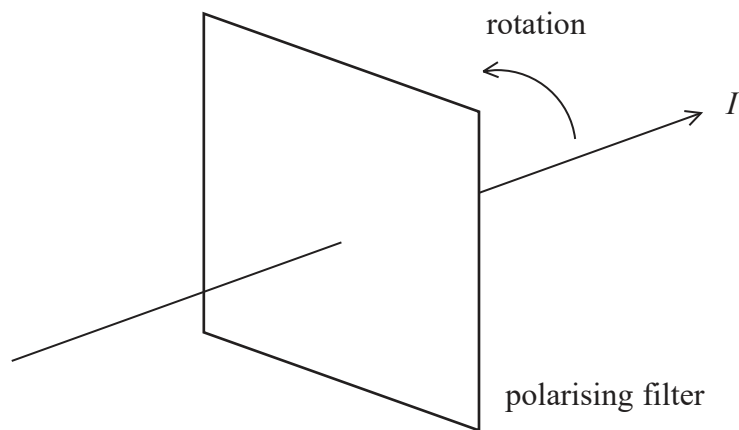

The polarising filter is then rotated in the direction shown on the diagram.

Which of the following gives the intensity of light transmitted after the filter has been rotated  $90^\circ$ ?

- A 0
- B  $\frac{I}{4}$
- C  $\frac{I}{2}$
- D  $I$

(Total for Question 4 = 1 mark)

DO NOT WRITE IN THIS AREA

DO NOT WRITE IN THIS AREA

DO NOT WRITE IN THIS AREA



DO NOT WRITE IN THIS AREA

- 5 A laser, diffraction grating and screen are set up as shown. The position of the central maximum is O and the position of the first order maximum is X.

The diffraction grating has 300 lines per mm.

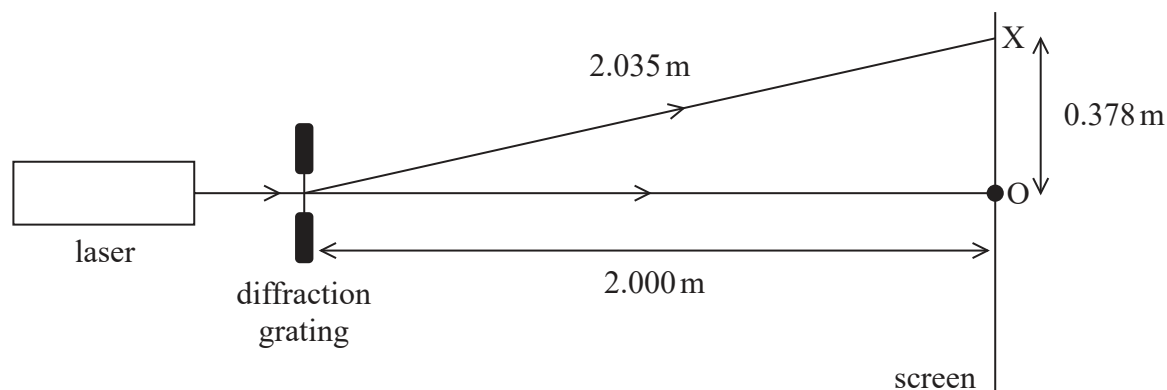

Which of the following expressions gives the wavelength of the laser light?

- A  $(300\,000) \times \left(\frac{0.378}{2.000}\right)$
- B  $(300\,000) \times \left(\frac{0.378}{2.035}\right)$
- C  $\left(\frac{1}{300\,000}\right) \times \left(\frac{0.378}{2.000}\right)$
- D  $\left(\frac{1}{300\,000}\right) \times \left(\frac{0.378}{2.035}\right)$

(Total for Question 5 = 1 mark)

- 6 At a point in a circuit there is a current of 3.0 A.

Which of the following gives the total charge passing this point in 2.0 minutes?

- A 0.025 C
- B 1.5 C
- C 6.0 C
- D 360 C

(Total for Question 6 = 1 mark)

DO NOT WRITE IN THIS AREA



P 7 0 9 6 9 R A 0 5 2 8

- 7 The diagram shows an electron transition between two energy levels in a hydrogen atom.

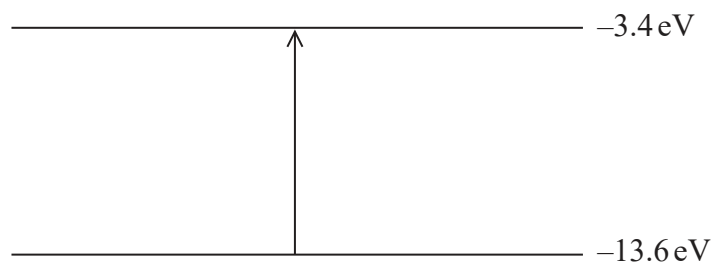

Which of the following could **not** have caused this transition?

- A The atom absorbing a photon with an energy of 13.6 eV.
- B The atom absorbing a photon with an energy of 10.2 eV.
- C An electron with a kinetic energy of 13.6 eV colliding with the atom.
- D An electron with a kinetic energy of 10.2 eV colliding with the atom.

(Total for Question 7 = 1 mark)

- 8 A battery is connected to identical, uniform, nichrome wires, PQ and RS. A voltmeter is connected to the wires as shown. The battery has negligible internal resistance.

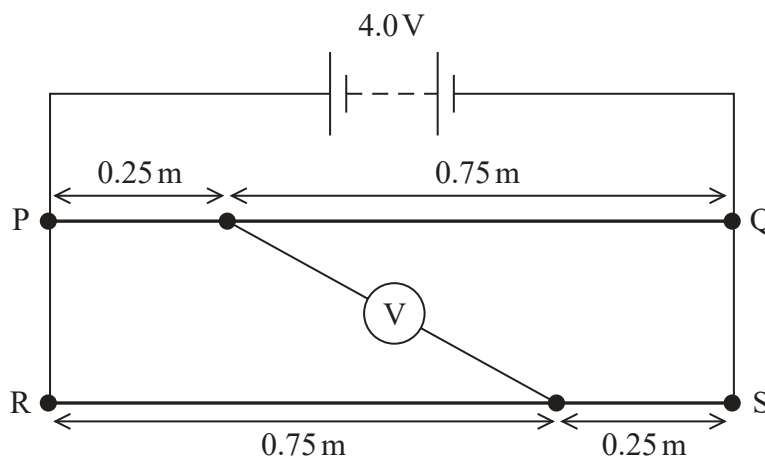

Which of the following is the reading on the voltmeter?

- A 1.0V
- B 2.0V
- C 3.0V
- D 4.0V

(Total for Question 8 = 1 mark)



- 9 The number of conduction electrons in a light dependent resistor changes as light intensity increases.

Which of the following best explains how the number of conduction electrons changes?

- A It decreases because the lattice ions vibrate with a larger amplitude.
- B It increases because the lattice ions vibrate with a larger amplitude.
- C It increases because the electrons gain energy from the photons of light.
- D It decreases because electrons are released due to the photoelectric effect.

(Total for Question 9 = 1 mark)

- 10 In 1927, G P Thomson first demonstrated that electrons passing through a nickel crystal produce a diffraction pattern.

Which of the following can be concluded from this observation?

- A Electrons behave as particles.
- B Electrons behave as waves.
- C Electrons behave as both particles and waves.
- D Electrons behave as neither particles nor waves.

(Total for Question 10 = 1 mark)

**TOTAL FOR SECTION A = 10 MARKS**



**SECTION B**

**Answer ALL questions in the spaces provided.**

**11** The diagram shows a ray of light incident on a glass block.

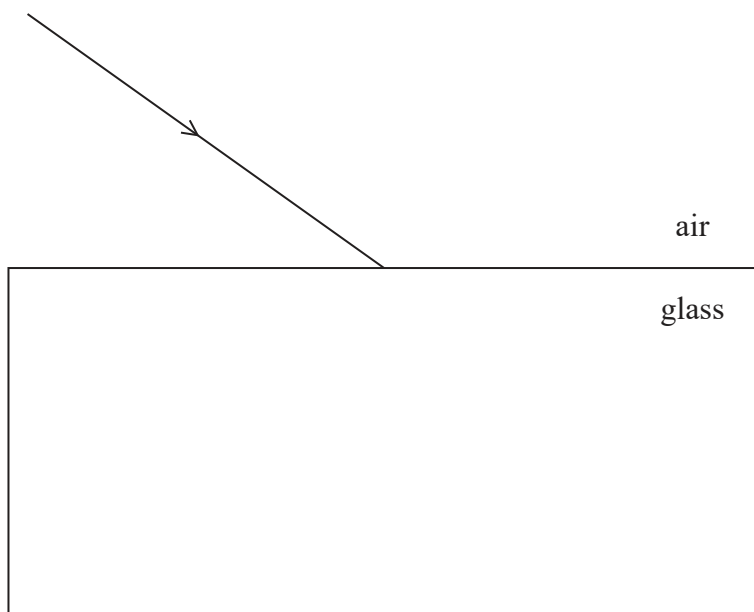

(a) Complete the diagram to show the path of the ray as it enters the block. Use the space below for any calculations.

refractive index of glass = 1.58

(5)

.....

.....

.....

.....

.....

.....

.....

DO NOT WRITE IN THIS AREA

DO NOT WRITE IN THIS AREA

DO NOT WRITE IN THIS AREA







12 A student set up the circuit shown. The battery had a negligible internal resistance.

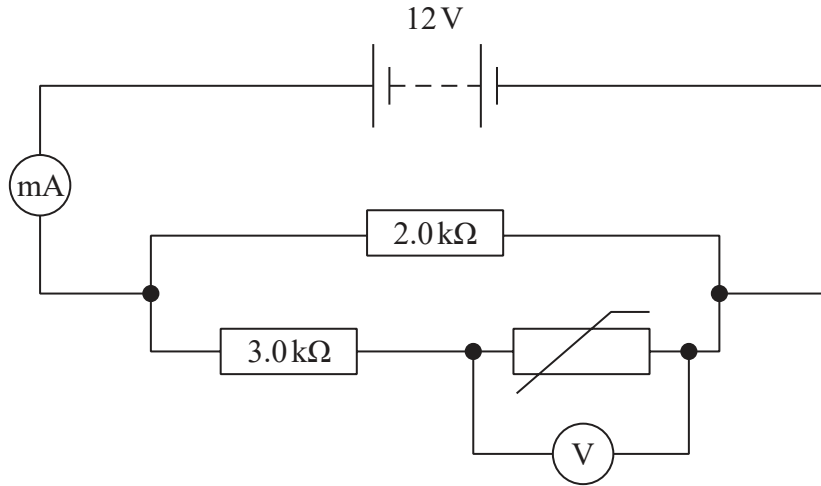

The resistance of the thermistor varies with temperature, as shown by the graph.

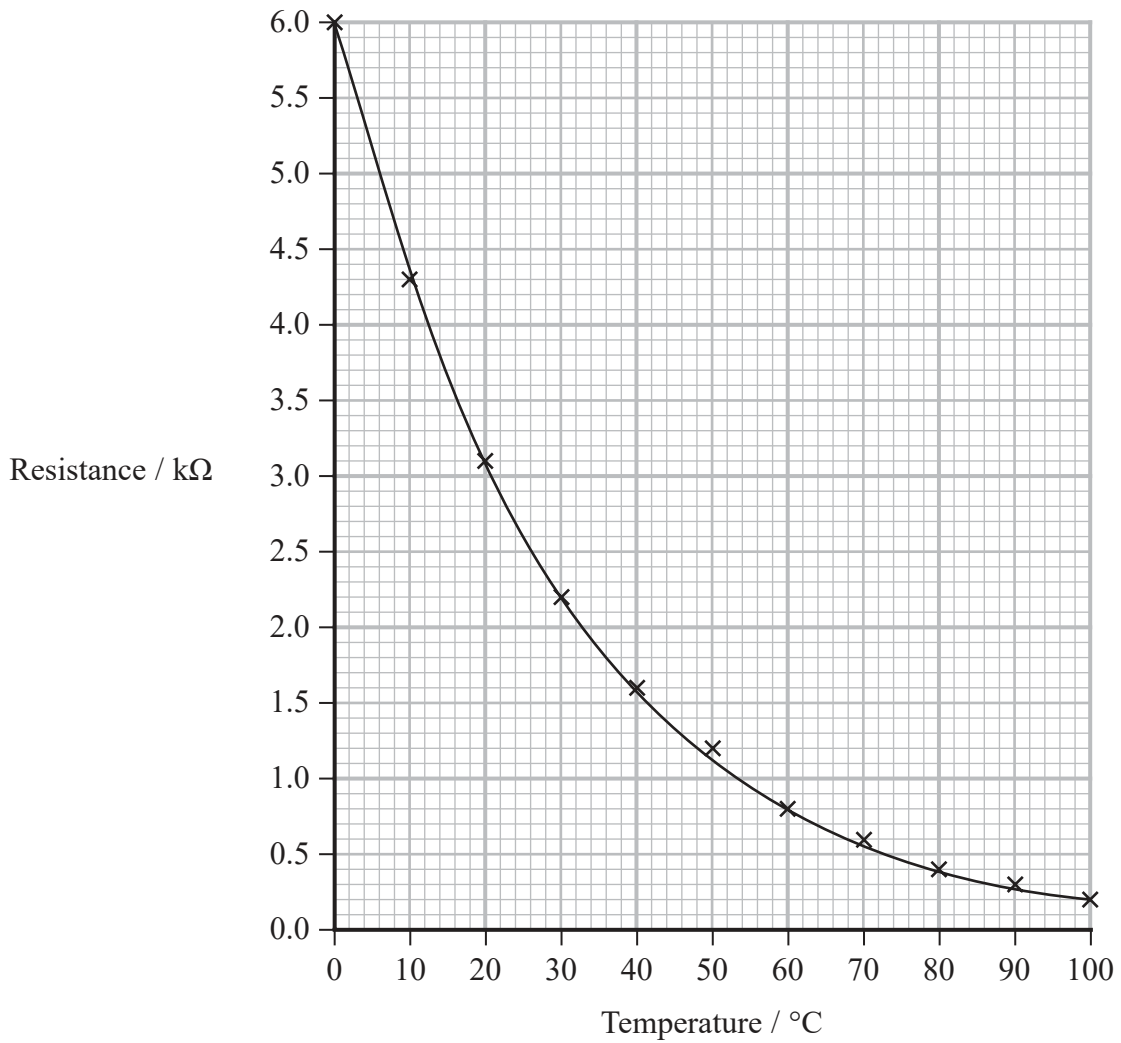

DO NOT WRITE IN THIS AREA

DO NOT WRITE IN THIS AREA

DO NOT WRITE IN THIS AREA



DO NOT WRITE IN THIS AREA

DO NOT WRITE IN THIS AREA

DO NOT WRITE IN THIS AREA

(a) Determine the milliammeter reading when the temperature of the thermistor is  $54^{\circ}\text{C}$ .

(4)

.....

.....

.....

.....

.....

.....

.....

.....

.....

Milliammeter reading = ..... mA

(b) (i) Explain how decreasing the temperature of the thermistor affects the voltmeter reading. Do not include calculations in your answer.

(2)

.....

.....

.....

.....

(ii) Explain how decreasing the temperature of the thermistor affects the power dissipated by the  $2.0\text{ k}\Omega$  resistor. Do not include calculations in your answer.

(2)

.....

.....

.....

.....

**(Total for Question 12 = 8 marks)**



13 The photograph shows a thin, coiled, tungsten wire used in a filament light bulb.

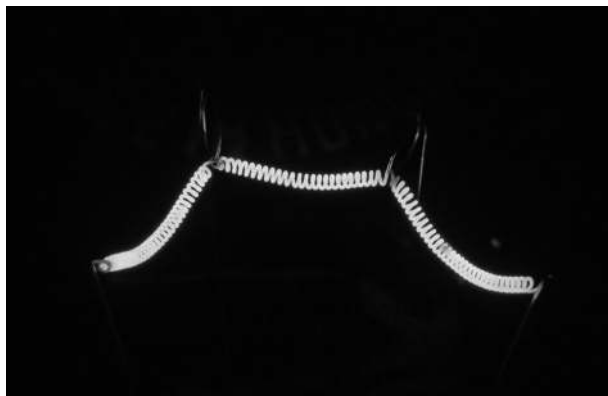

(Source: © goran cakmazovic/Shutterstock)

(a) Complete the sketch graph to show how current varies with potential difference for a filament bulb.

(2)

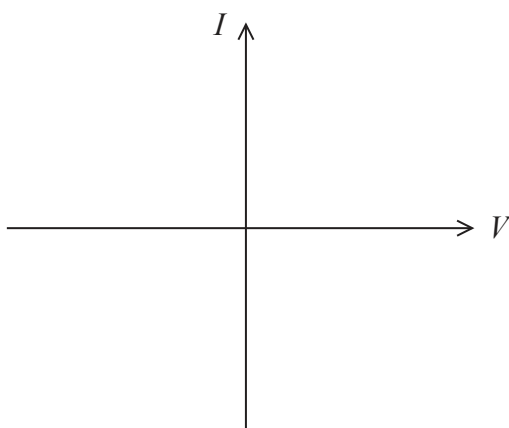

DO NOT WRITE IN THIS AREA

DO NOT WRITE IN THIS AREA

DO NOT WRITE IN THIS AREA



(b) The tungsten wire has a diameter of 0.046 mm and a length of 580 mm. When emitting light, there is a current of 0.44 A in the filament and a potential difference of 140 V across the filament.

(i) Calculate the drift velocity  $v$  of the electrons in the tungsten wire.

number of charge carriers per  $\text{m}^3$  in tungsten =  $1.26 \times 10^{29}$  (3)

$v =$  .....

(ii) When the potential difference across the tungsten filament is 140 V the current in the filament is 0.44 A.

The table shows typical resistivity values for tungsten at different temperatures.

Temperature / $^{\circ}\text{C}$	20	700	1700	2700	3200
Resistivity / $\Omega\text{m}$	$0.55 \times 10^{-7}$	$2.43 \times 10^{-7}$	$5.57 \times 10^{-7}$	$9.04 \times 10^{-7}$	$10.85 \times 10^{-7}$

Deduce the temperature of the filament. (3)

(Total for Question 13 = 8 marks)



14 When an earthquake occurs, two types of wave travel through the Earth. The two types of wave are P-waves (longitudinal) and S-waves (transverse).

- (a) The velocities of P-waves and S-waves as they travel through the Earth are related to the density  $\rho$  of the material they are travelling through.

The velocity  $v_p$  of P-waves and the velocity  $v_s$  of S-waves are given by the following equations:

$$v_p = \sqrt{\frac{K + \frac{4}{3}G}{\rho}} \qquad v_s = \sqrt{\frac{G}{\rho}}$$

where  $K$  and  $G$  are constants for a particular material below the Earth's surface.

- (i) The density of one material is  $2700 \text{ kg m}^{-3}$ .

Calculate  $v_p$  and  $v_s$  in this material.

$$K = 7.55 \times 10^{10} \text{ Pa}$$

$$G = 2.61 \times 10^{10} \text{ Pa}$$

(4)

$$v_p = \dots\dots\dots$$

$$v_s = \dots\dots\dots$$

- (ii) The Earth contains layers of liquid. The value of  $G$  for liquids is 0.

Explain whether S-waves can travel through liquids.

(2)



(b) During a single earthquake, S-waves can be produced by more than one source. If two coherent S-waves meet, interference can take place.

(i) Explain what is meant by coherent.

(2)

.....

.....

.....

.....

(ii) A scientist created a model to predict the effect of two coherent S-waves at different distances from the source. The model predicted the amplitude of the S-waves at positions A and B shown on the diagram.



The amplitude of the waves at position A was zero. The amplitude of the waves at position B was greater than zero.

Explain why the amplitude of the waves at position A was zero.

(3)

.....

.....

.....

.....

.....

.....

.....

(Total for Question 14 = 11 marks)



15 The diagram shows a circuit containing three identical resistors, A, B and C. The cell has negligible internal resistance.

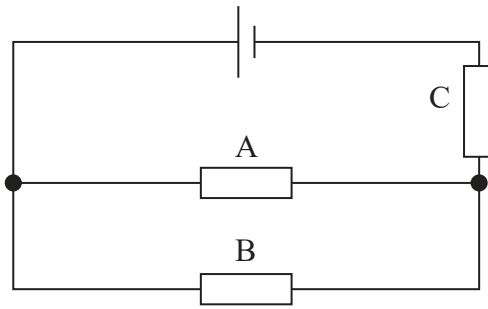

\*(a) Explain how measurements of current and potential difference could be used to demonstrate that charge and energy are both conserved in this circuit. Your answer should refer to resistors A, B and C.

(6)

.....

.....

.....

.....

.....

.....

.....

.....

.....

.....

.....

.....

.....

.....

.....

.....

.....

.....

.....

.....

.....

.....

DO NOT WRITE IN THIS AREA

DO NOT WRITE IN THIS AREA

DO NOT WRITE IN THIS AREA





- (b) (i) Calculate the total resistance of the circuit.

resistance of each resistor =  $12.5 \Omega$

(3)

Total resistance = .....

- (ii) The resistors are connected to a different cell, with e.m.f.  $\mathcal{E}$ , as shown. The cell has an internal resistance.

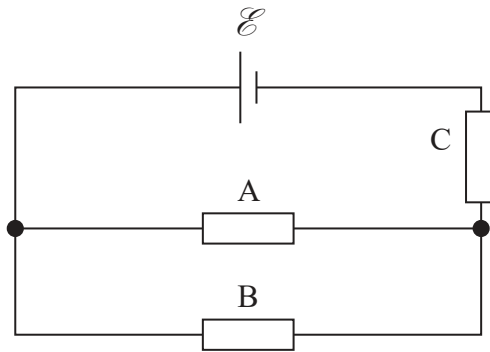

Describe how a single ammeter reading can be used to determine the internal resistance of the cell. You should add to the diagram to show the position of this ammeter.

(3)

(Total for Question 15 = 12 marks)



16 A student investigated stationary waves on a stretched string. The string was attached to a vibrator and a mass  $M$ , as shown.

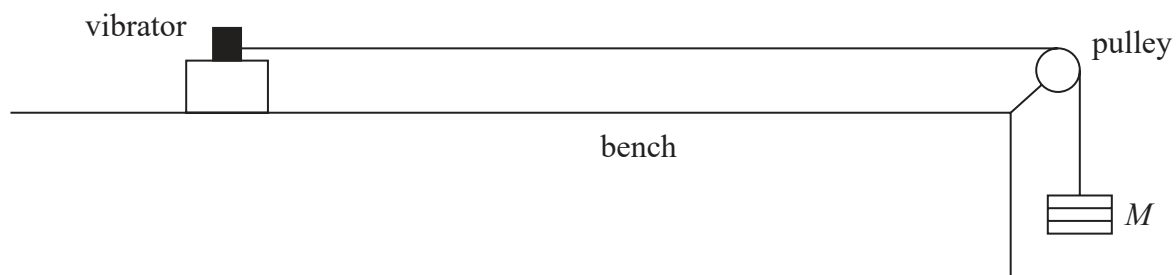

(a) Explain how a stationary wave forms on the string.

(3)

.....

.....

.....

.....

.....

.....

DO NOT WRITE IN THIS AREA

DO NOT WRITE IN THIS AREA

DO NOT WRITE IN THIS AREA





- (c) The mass  $M$  was changed and the frequency of the vibrator was adjusted, so that a different stationary wave formed on the string. Adjacent nodes were separated by  $0.400\text{ m}$ . The diagram shows two points, S and T, on the string at an instant when the string was straight.

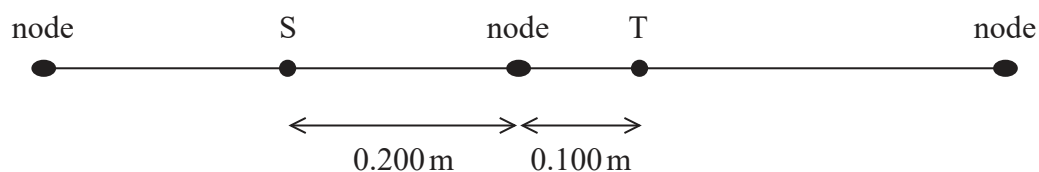

- (i) Explain the phase relationship between points S and T. (2)

.....

.....

.....

.....

- (ii) Explain how the amplitude of vibration of the string at point S compares with the amplitude of vibration of the string at point T. (2)

.....

.....

.....

.....

(Total for Question 16 = 12 marks)



DO NOT WRITE IN THIS AREA

DO NOT WRITE IN THIS AREA

DO NOT WRITE IN THIS AREA

**BLANK PAGE**



P 7 0 9 6 9 R A 0 2 1 2 8

17 Ultraviolet light is incident on a zinc plate. If the photon energy is greater than the work function of the zinc, electrons are released.

(a) State what is meant by work function.

(1)

(b) The ultraviolet (UV) section of the electromagnetic spectrum can be split into three parts, known as UVA, UVB and UVC. The range of wavelengths of these parts is given in the table.

	UVC	UVB	UVA
Range of wavelength / nm	200–280	280–320	320–400

The minimum de Broglie wavelength of the released electrons is  $1.50 \times 10^{-9}$  m.

Deduce whether the ultraviolet light incident upon the zinc plate is UVA, UVB or UVC.

work function of zinc = 4.30 eV

(6)



- (c) A student used a zinc plate and UV light of different frequencies in an experiment. The student's graph of maximum kinetic energy of the released electrons against the frequency of the incident UV light is shown.

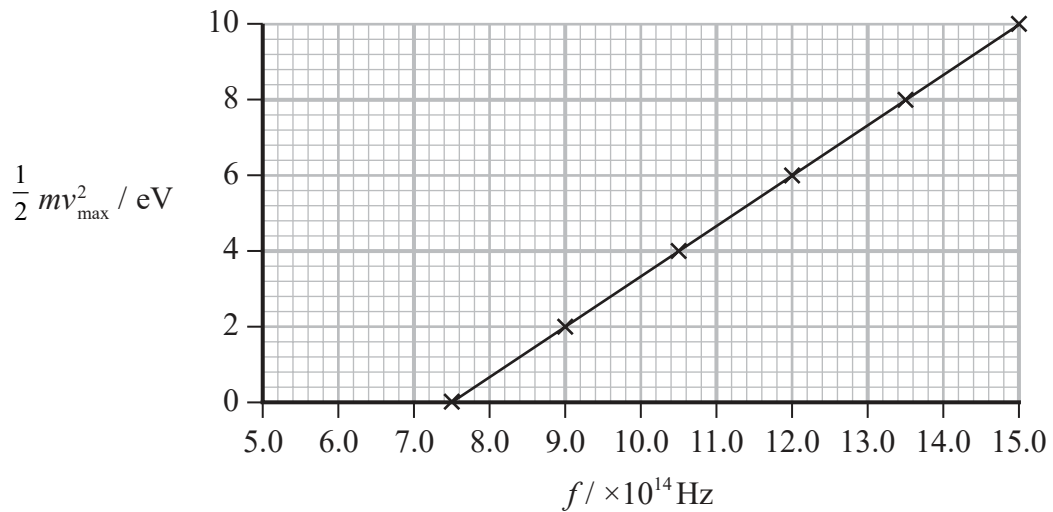

Einstein's photoelectric equation applies to this situation.

$$hf = \phi + \frac{1}{2} mv_{\text{max}}^2$$

Describe two ways that the graph is **not** consistent with the values known for a zinc plate. Your answer should include calculations.

work function of zinc = 4.30 eV

(4)

(Total for Question 17 = 11 marks)

**TOTAL FOR SECTION B = 70 MARKS**

**TOTAL FOR PAPER = 80 MARKS**



### List of data, formulae and relationships

Acceleration of free fall	$g = 9.81 \text{ m s}^{-2}$	(close to Earth's surface)
Electron charge	$e = -1.60 \times 10^{-19} \text{ C}$	
Electron mass	$m_e = 9.11 \times 10^{-31} \text{ kg}$	
Electronvolt	$1 \text{ eV} = 1.60 \times 10^{-19} \text{ J}$	
Gravitational field strength	$g = 9.81 \text{ N kg}^{-1}$	(close to Earth's surface)
Planck constant	$h = 6.63 \times 10^{-34} \text{ J s}$	
Speed of light in a vacuum	$c = 3.00 \times 10^8 \text{ m s}^{-1}$	

### Unit 1

#### Mechanics

Kinematic equations of motion

$$s = \frac{(u + v)t}{2}$$

$$v = u + at$$

$$s = ut + \frac{1}{2}at^2$$

$$v^2 = u^2 + 2as$$

#### Forces

$$\Sigma F = ma$$

$$g = \frac{F}{m}$$

$$W = mg$$

#### Momentum

$$p = mv$$

#### Moment of force

$$\text{moment} = Fx$$

#### Work and energy

$$\Delta W = F\Delta s$$

$$E_k = \frac{1}{2}mv^2$$

$$\Delta E_{\text{grav}} = mg\Delta h$$

#### Power

$$P = \frac{E}{t}$$

$$P = \frac{W}{t}$$

DO NOT WRITE IN THIS AREA

DO NOT WRITE IN THIS AREA

DO NOT WRITE IN THIS AREA





Efficiency

$$\text{efficiency} = \frac{\text{useful energy output}}{\text{total energy input}}$$

$$\text{efficiency} = \frac{\text{useful power output}}{\text{total power input}}$$

*Materials*

Density

$$\rho = \frac{m}{V}$$

Stokes' law

$$F = 6\pi\eta rv$$

Hooke's law

$$\Delta F = k\Delta x$$

Elastic strain energy

$$\Delta E_{\text{el}} = \frac{1}{2}F\Delta x$$

Young modulus

$$E = \frac{\sigma}{\varepsilon} \text{ where}$$

$$\text{Stress } \sigma = \frac{F}{A}$$

$$\text{Strain } \varepsilon = \frac{\Delta x}{x}$$

DO NOT WRITE IN THIS AREA

DO NOT WRITE IN THIS AREA

DO NOT WRITE IN THIS AREA



**Unit 2***Waves*

Wave speed	$v = f\lambda$
Speed of a transverse wave on a string	$v = \sqrt{\frac{T}{\mu}}$
Intensity of radiation	$I = \frac{P}{A}$
Refractive index	$n_1 \sin \theta_1 = n_2 \sin \theta_2$ $n = \frac{c}{v}$
Critical angle	$\sin C = \frac{1}{n}$
Diffraction grating	$n\lambda = d \sin \theta$

*Electricity*

Potential difference	$V = \frac{W}{Q}$
Resistance	$R = \frac{V}{I}$
Electrical power, energy	$P = VI$ $P = I^2R$ $P = \frac{V^2}{R}$ $W = VIt$
Resistivity	$R = \frac{\rho l}{A}$
Current	$I = \frac{\Delta Q}{\Delta t}$ $I = nqvA$
Resistors in series	$R = R_1 + R_2 + R_3$
Resistors in parallel	$\frac{1}{R} = \frac{1}{R_1} + \frac{1}{R_2} + \frac{1}{R_3}$

*Particle nature of light*

Photon model	$E = hf$
Einstein's photoelectric equation	$hf = \phi + \frac{1}{2}mv_{\max}^2$
de Broglie wavelength	$\lambda = \frac{h}{p}$



DO NOT WRITE IN THIS AREA

DO NOT WRITE IN THIS AREA

DO NOT WRITE IN THIS AREA

**BLANK PAGE**



DO NOT WRITE IN THIS AREA

DO NOT WRITE IN THIS AREA

DO NOT WRITE IN THIS AREA

**BLANK PAGE**

